

1

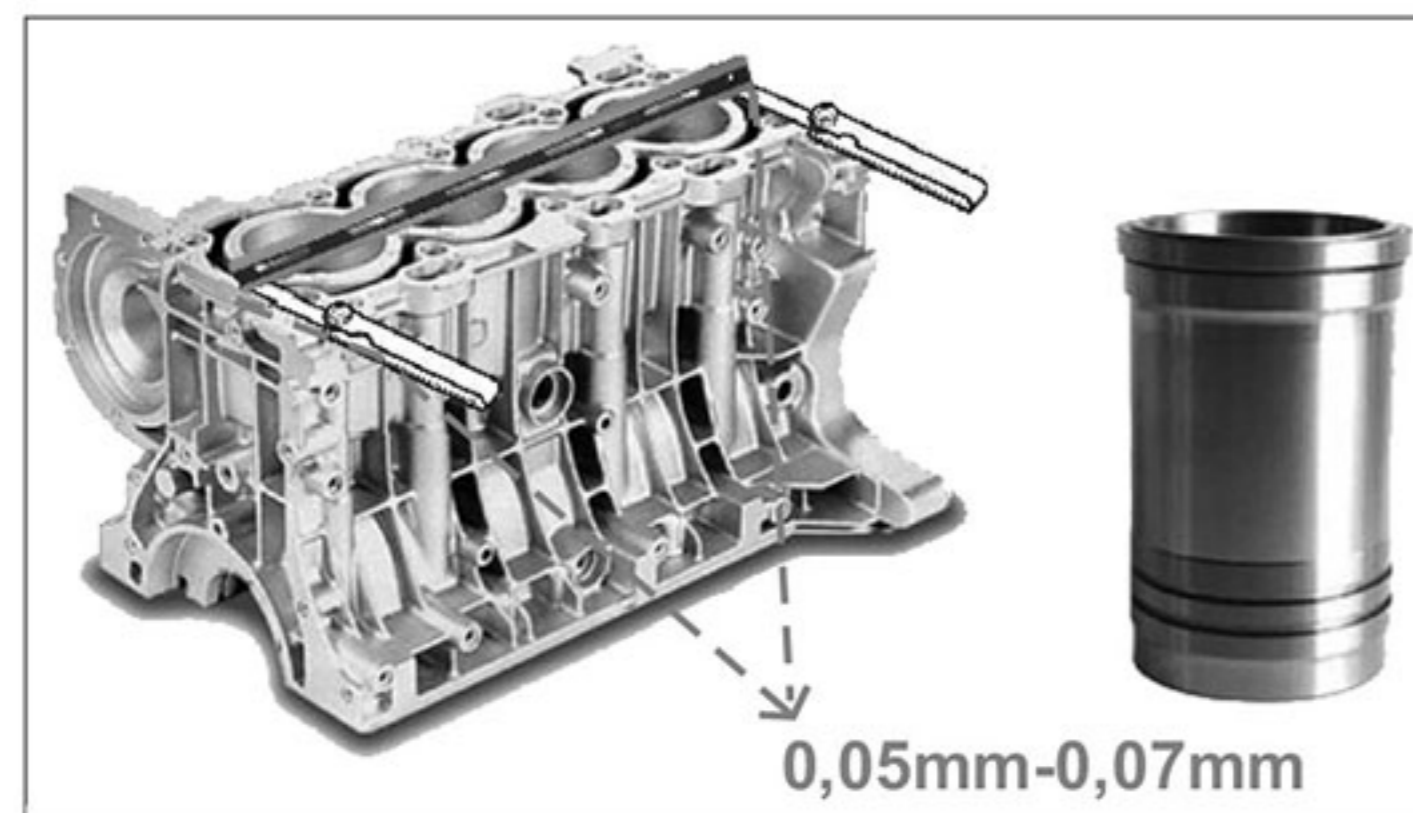

2

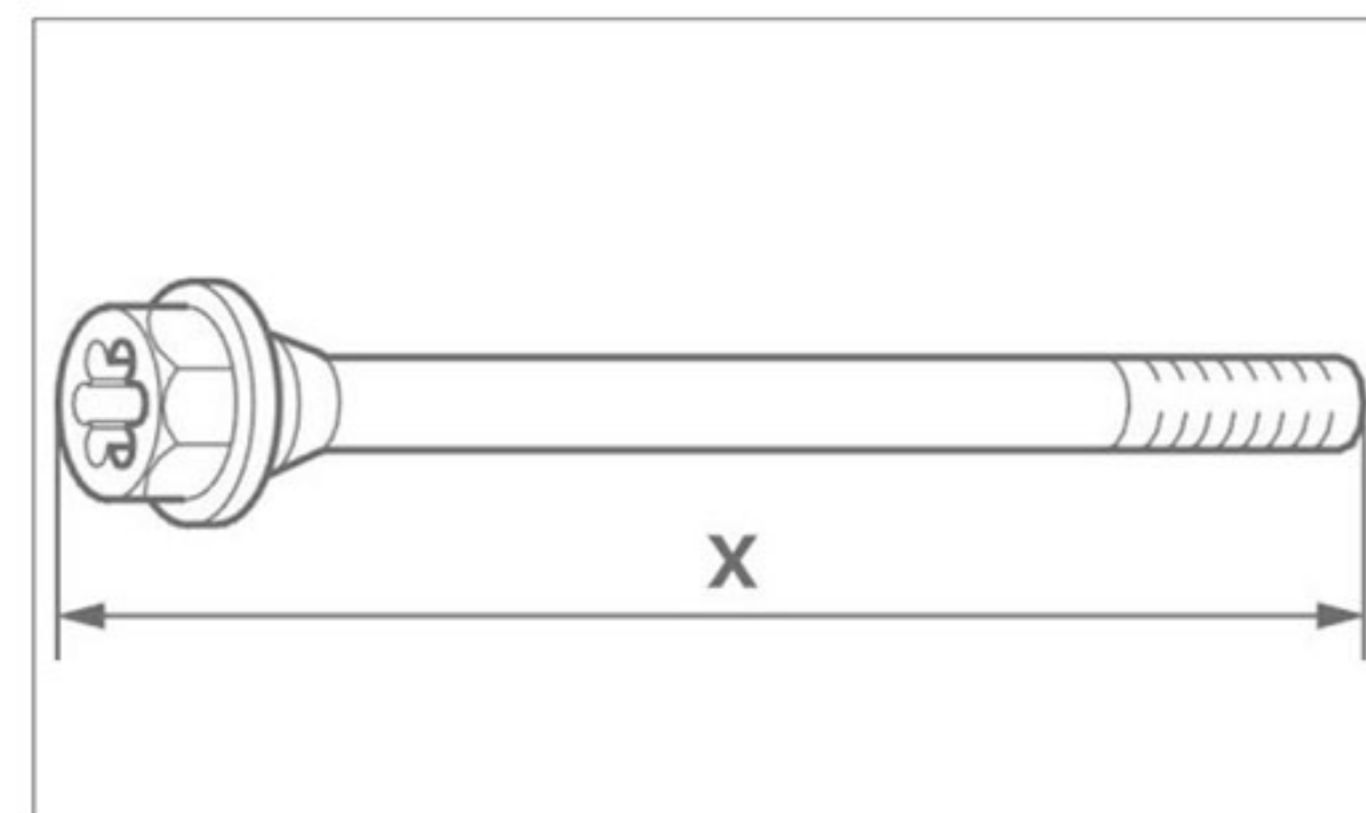

3

1.3-1 CHECKING THE FLATNESS
Maximum permissible bow = 0,05mm

3. (X) must be less than 176,5 mm.
CHECKING CYLINDER HEAD BOLTS
BEFORE RE-USE.
Clean out the cylinder head bolt
holes in the cylinder block with a tap .

5.4-1 CYLINDER HEAD TIGHTENING.
Fit the cylinder head cover / air cleaner
assembly using a new seal .
Tighten the ten bolts, in the order shown, to
1 da.Nm .
Replace the inlet manifolds fitted with new
seals Tightening torque 2 da.Nm .
Continue the fitting operations in the reverse
order to removal .
Bolt by bolt : slacken completely tighten to
2 da.Nm tighten a further 100 degrees using
a FACOM D.360 type tool.

4.Coat the threads and the contact area
under the bolt head with MOLYKOTE
G RAPIDE PLUS grease.

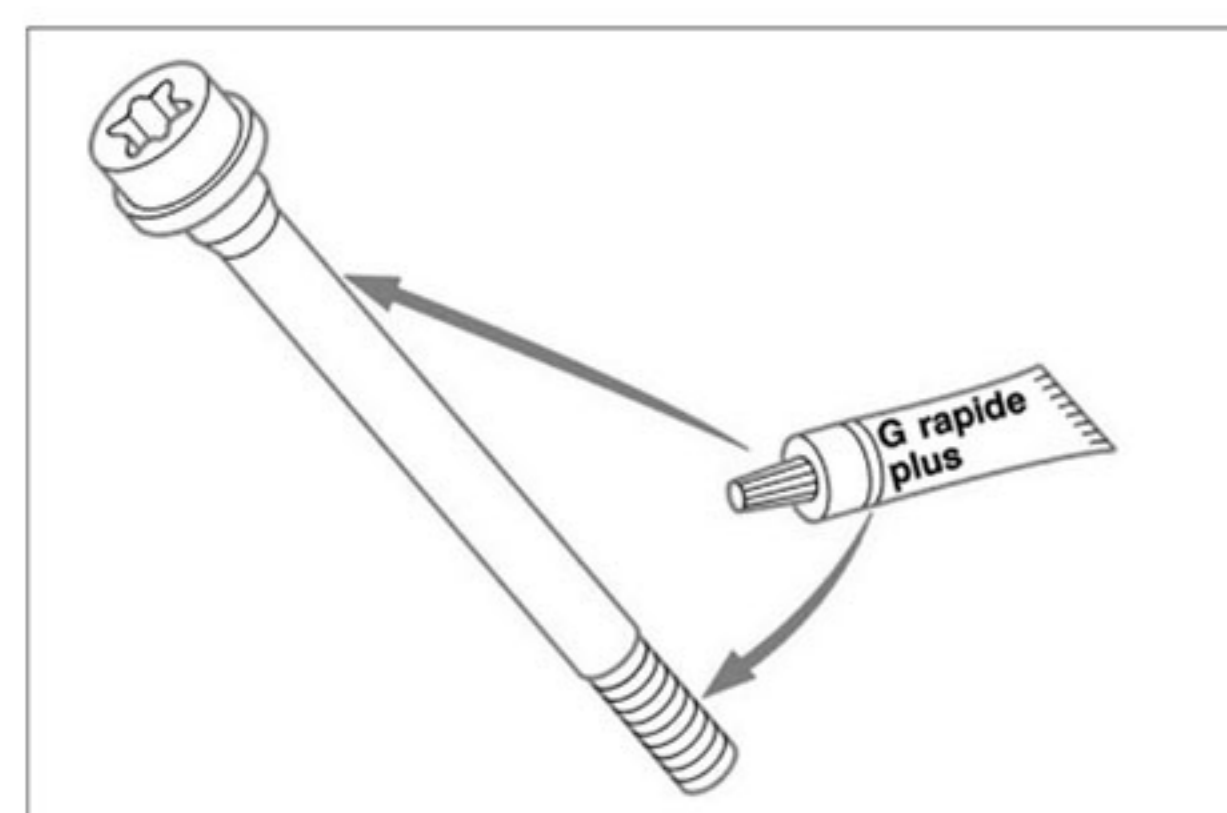

4

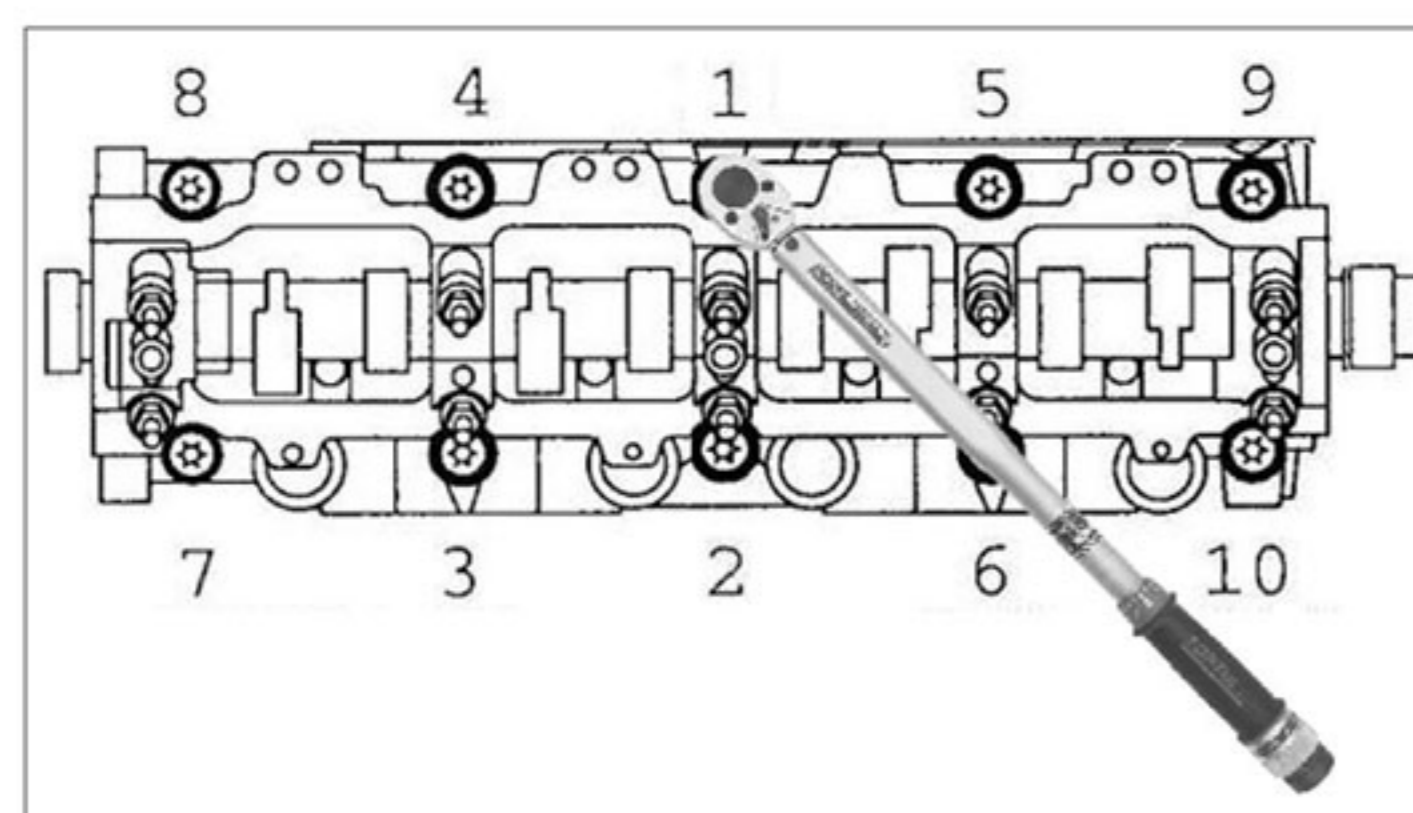

5

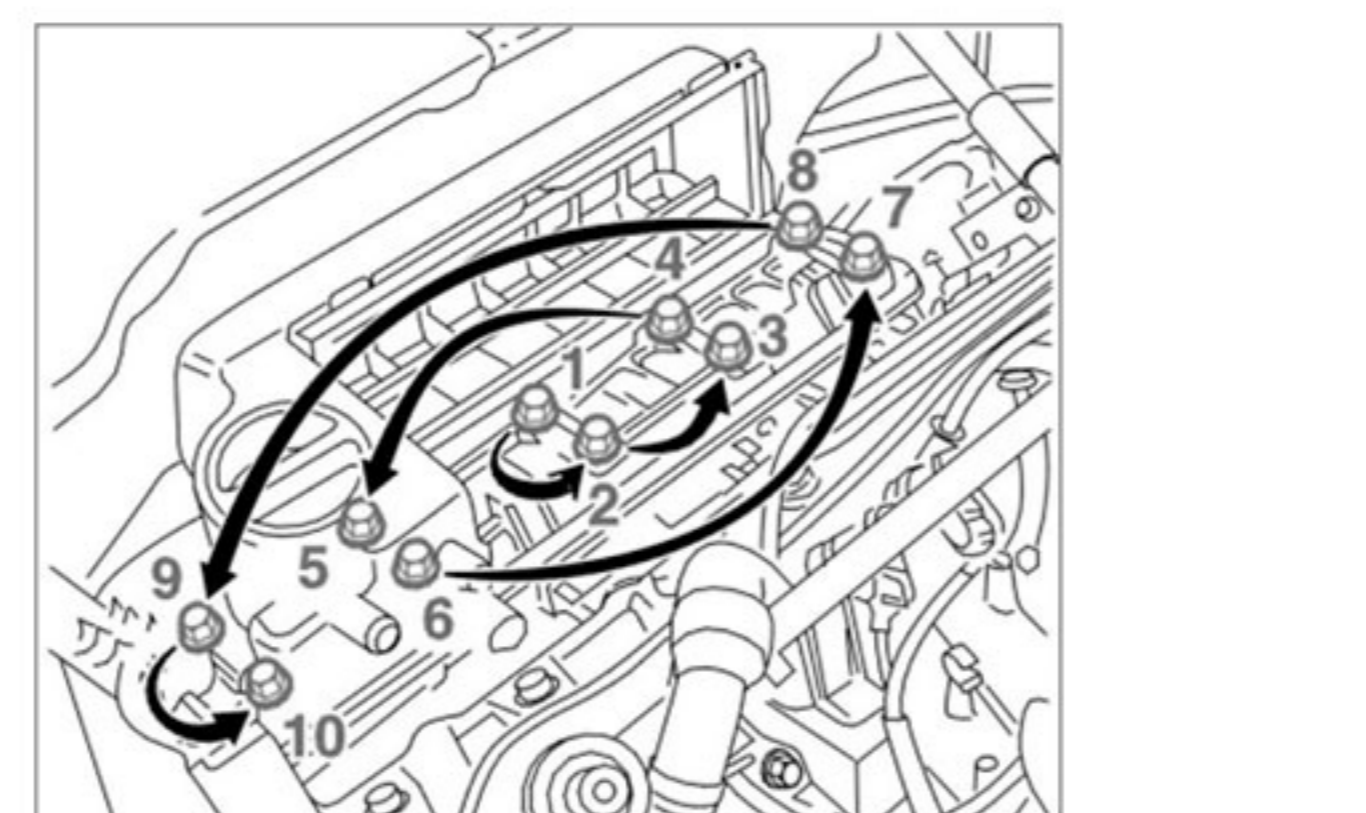

6

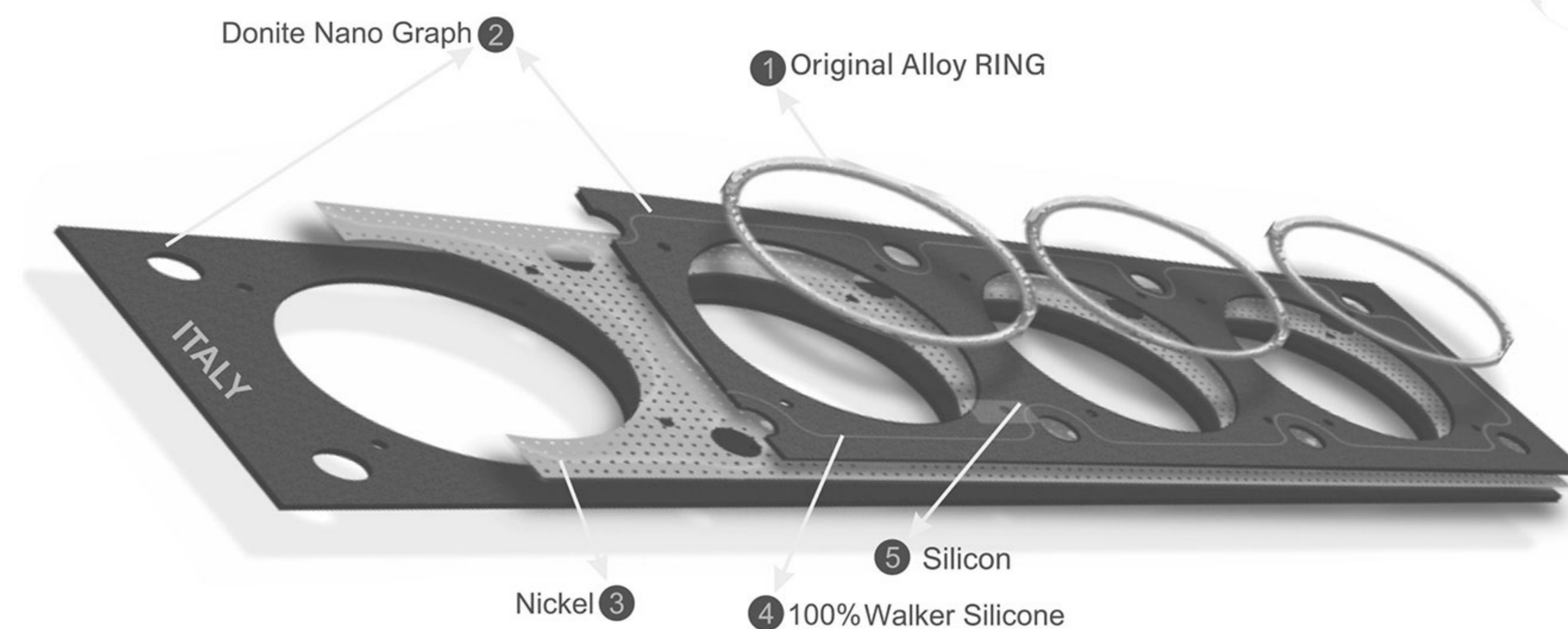

- OTAL Cylinder Head Gascet
- Compliant to Europe spare part standards
- GASCET ITALY ■



KAVIAN
SANAT FARTAK

کاتالوگ نصب واشر سر سیلندر xu7